

OFFICE FOR LEASE

Tualatin Business Center II

18101 SW Boones Ferry Road, Suite 125, Portland, OR 97224
Building 3



Key Features



522 sq. ft. office

Upgraded lobby finishes

Abundant parking

Excellent access to I-5

Less than a mile from a variety of amenities including Bridgeport Village

Lease Rate:

\$18.00/sq. ft./yr.
full service

Jake Bigby

jakeb@pacitrust.com

Caitlin Knecht

caitlink@pacitrust.com

503.624.6300

Owned & Managed by

PACTRUST

Space Plan

18101 SW Boones Ferry Road, Suite 125, Portland, OR 97224

522 Sq. Ft.

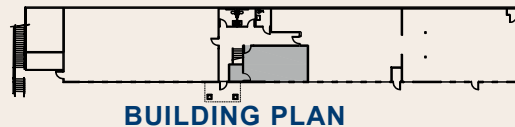
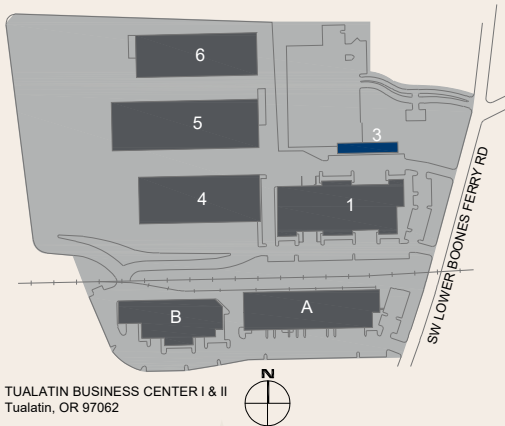
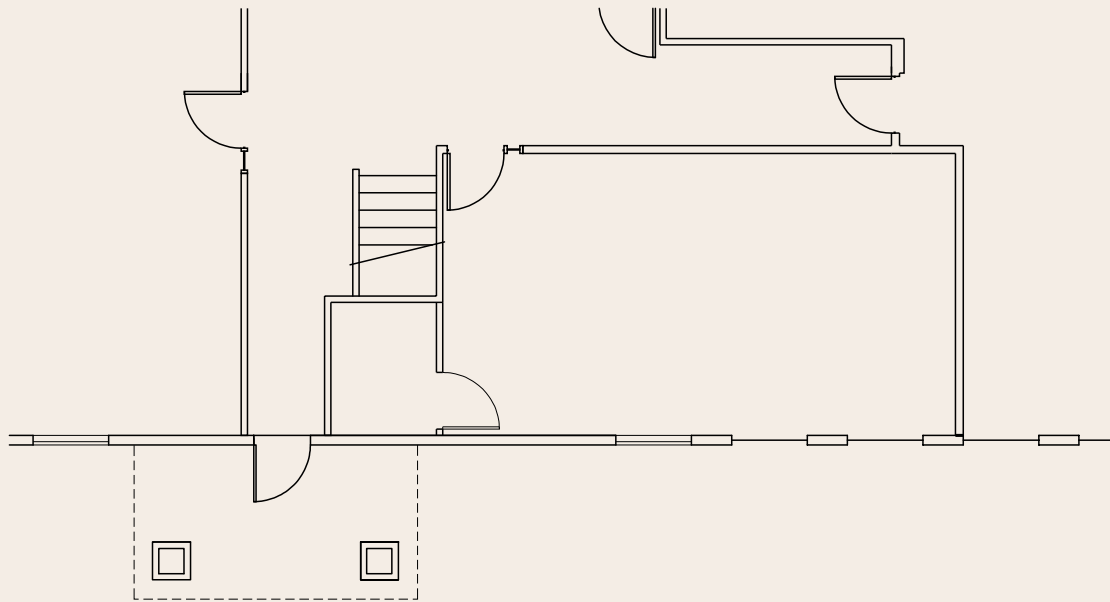

BUILDING PLAN

Jake Bigby
jakeb@pactrust.com

Caitlin Knecht
caitlink@pactrust.com

503.624.6300
www.PacTrust.com